

LUNAR RADIO TELESCOPE – RADIO FREQUENCY (RF) RECEIVER PCB DESIGN

Team 8: Jashley Bayani, Liam Kervin, Ethan McConnell, Diego Puerta

Mentor: Dr. Judd Bowman

INTRODUCTION

The FARSIDE lunar radio telescope aims to observe and measure very low-frequency (0.1 – 40 MHz) RF signals with longer wavelengths (7.5 m – 3 km) to study the “Dark Ages” of the Universe and exoplanet magnetospheres by using the Moon to shield itself from Earth’s radio interference.



This project aims to create the first prototype of the electronics node that will receive, condition, and transmit the signals from the antenna through RFoF to the receiver in the lander for signal processing.

CONCEPT & THEORY

The node will receive the RF signals from the antennas, separate them from the ac power, amplify them using high-impedance amplifiers, and convert them into optical signals by using RFoF technology to transmit the signal through fiber optics. The goal is to have clean signals without considering space environment.

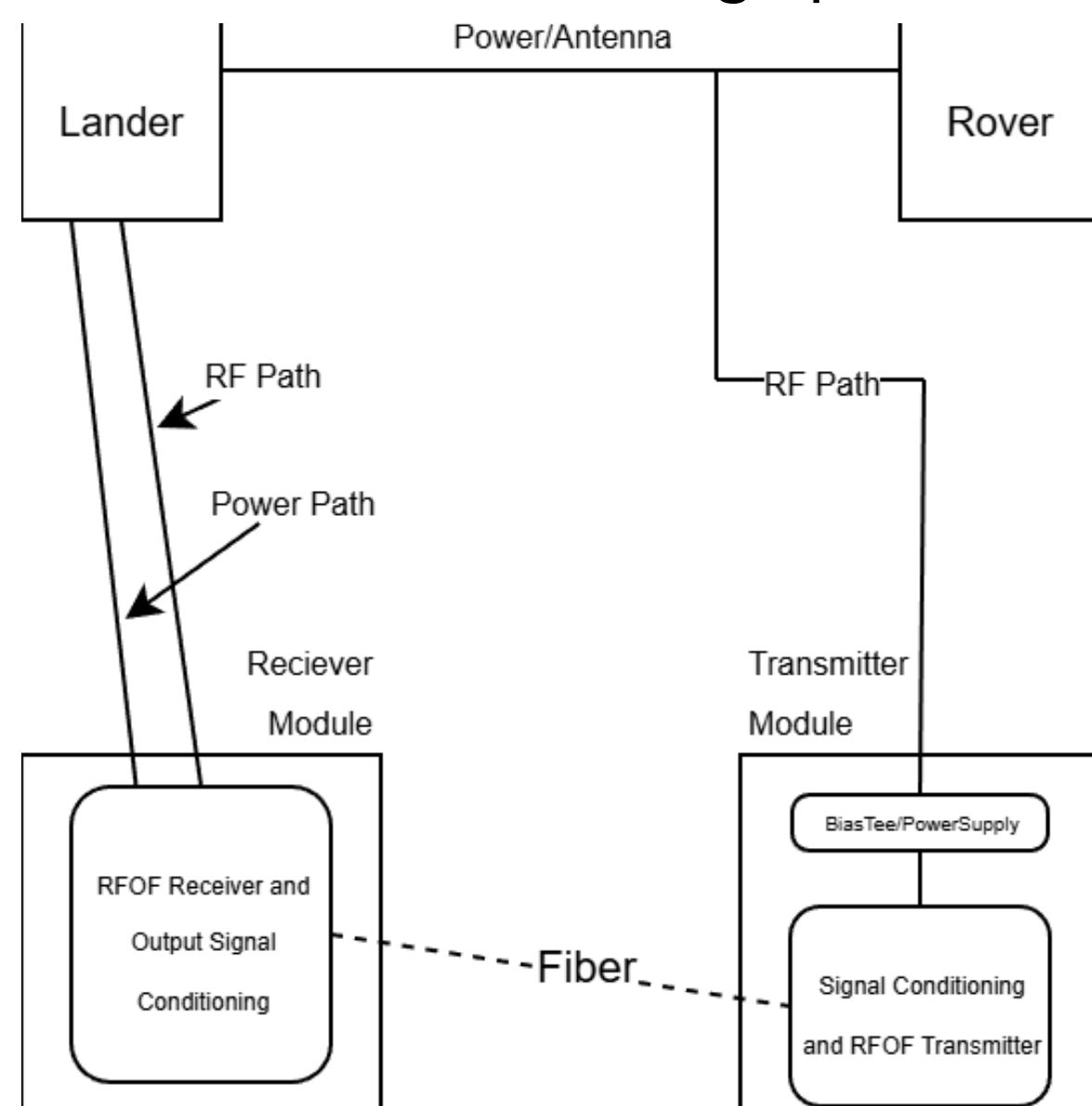

CIRCUIT SCHEMATICS

This project consists of 5 modules. The design for the transmitter and receiver circuits is based on the DSA-2000. These modules are used to setup the final node.

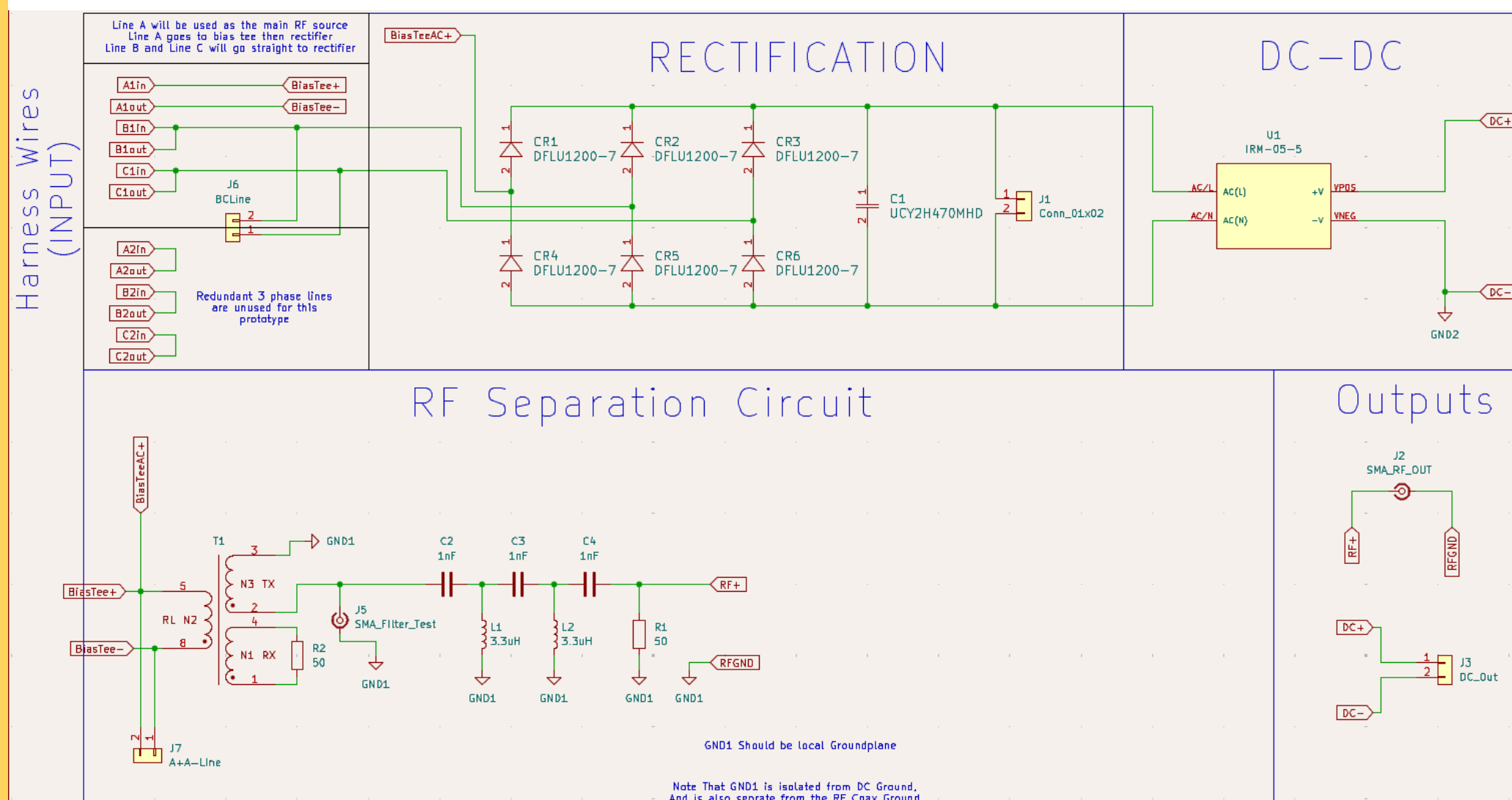

Input Board – includes bias tee and power supply

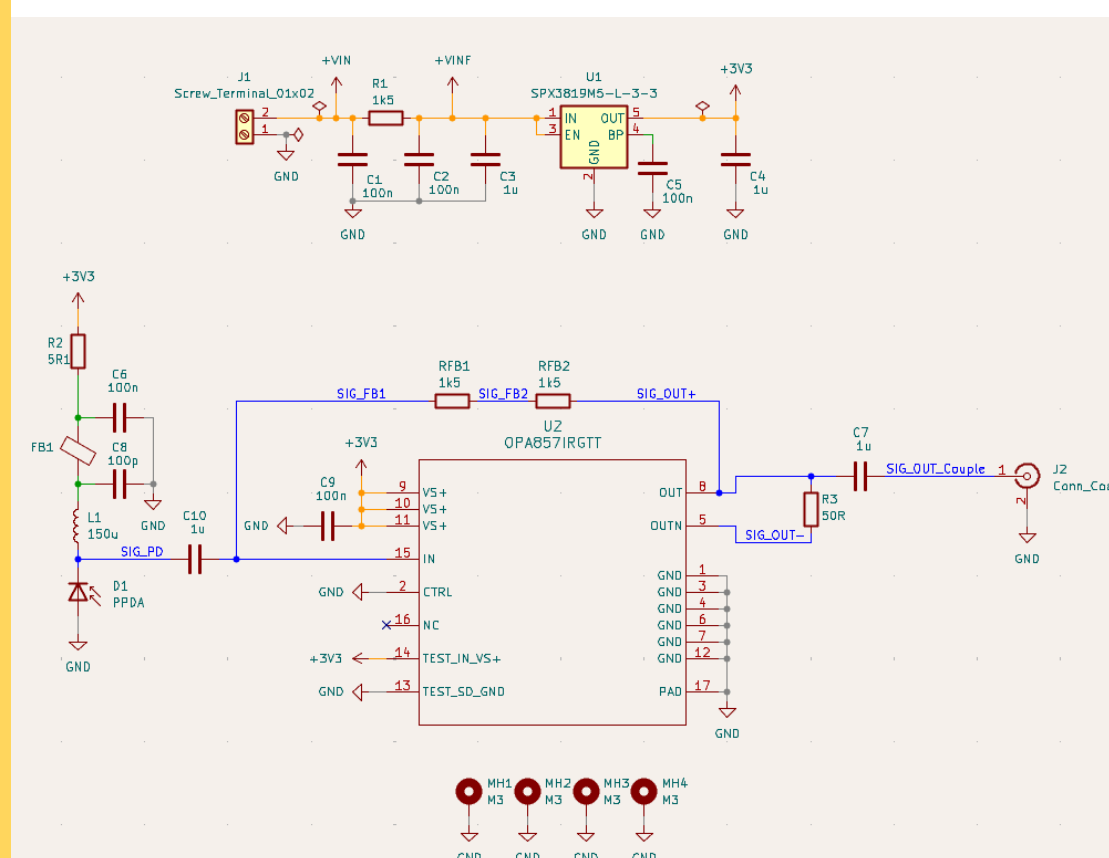

Transimpedance Amplifier (TIA) Module (only for receiver)

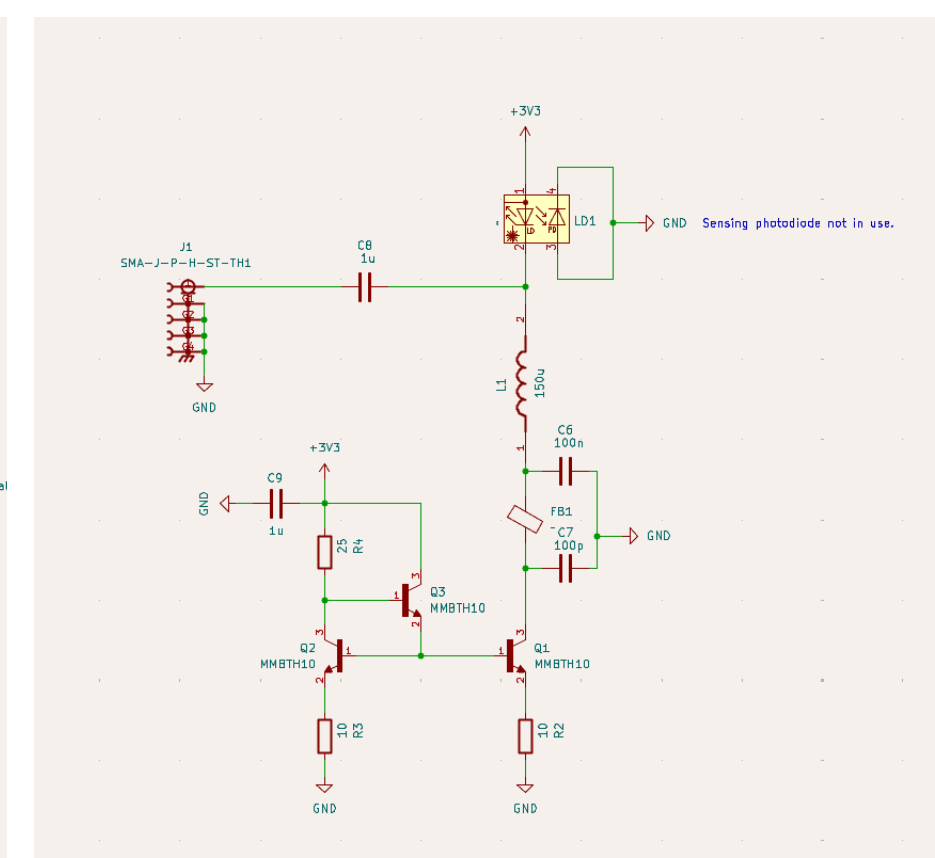

Laser Driver Module (only for transmitter)

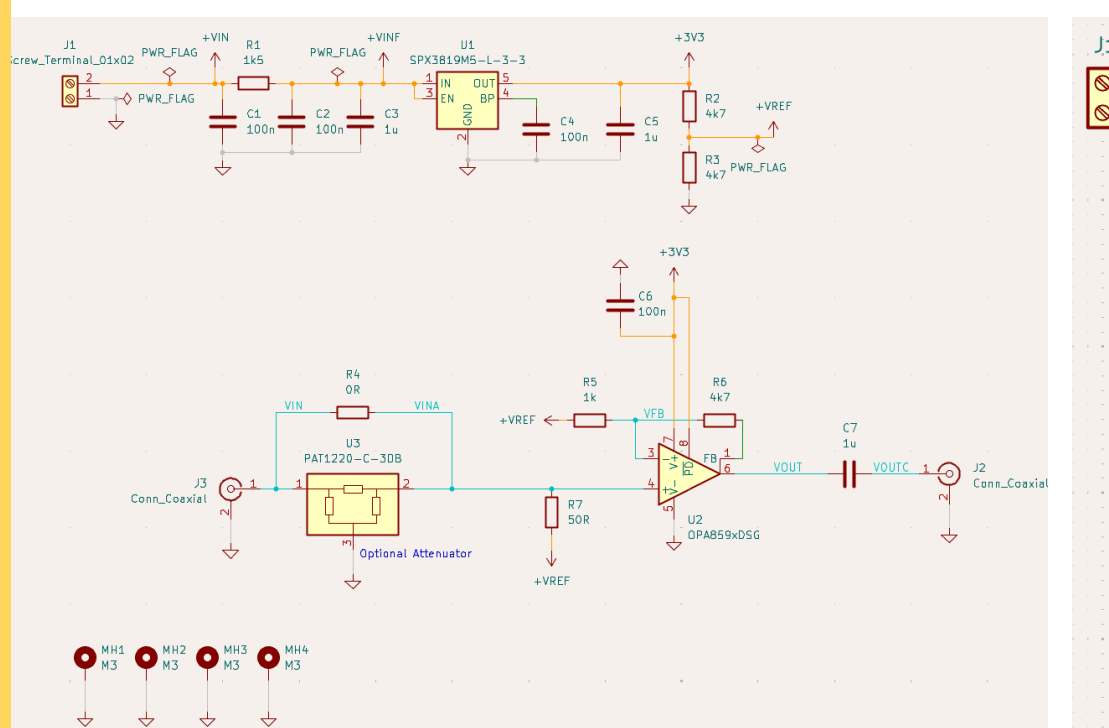

Gain Module (for both transmitter and receiver)

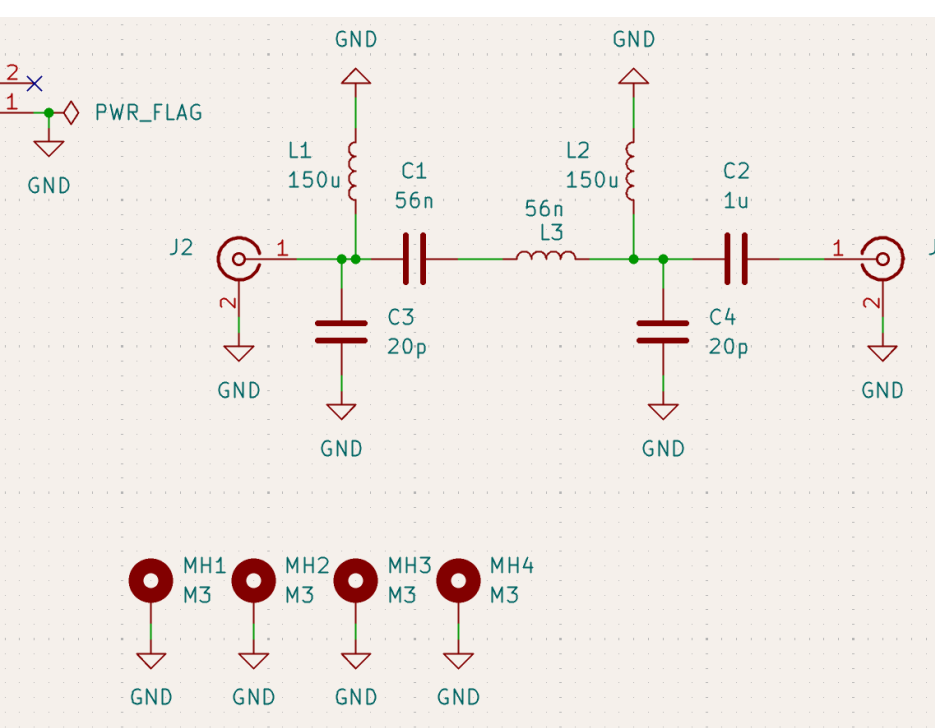

Filter Module

SIMULATION RESULTS & PROTOTYPE

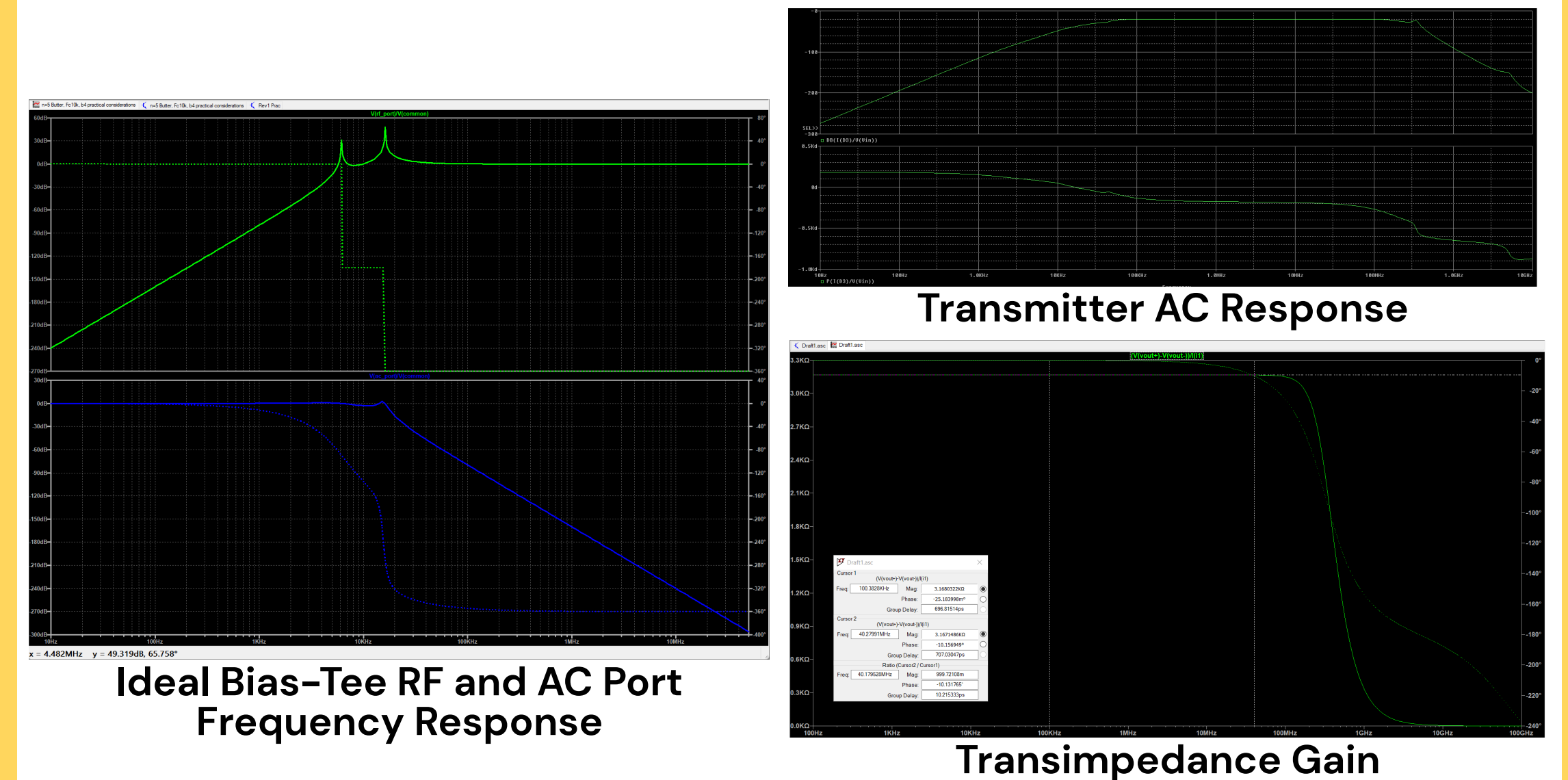

- For the input board with ideal components, results show that the RF and ac signal has been cleanly separated.
- The transmitter ac response demonstrate a flat pass band in the frequency range of interest as a stable system.
- The gain of the TIA has been lowered to maintain linearity up to 40 MHz, to ensure receiver stability.

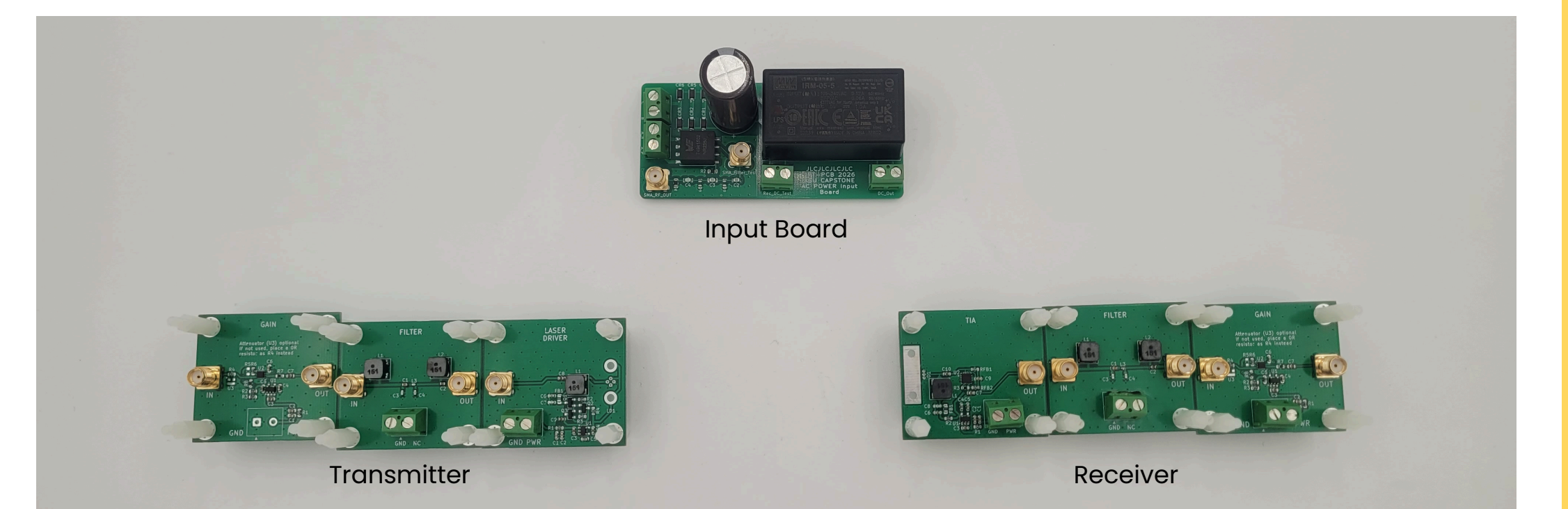

CONCLUSION

From the simulation results, the PCB nodes are expected to work as intended to. Further testing of the actual boards will be done to verify the signal-to-noise ratio to see if they give satisfactory results. These boards serve as the first prototype for the PCB node for FARSIDE to initiate further improvements such as accounting for the space environment.