

# Minimoog Reimagined: A Compact, Single-Board Redesign Using Modern Components and Simulation

Team 50 (Hybrid) - Members:  
 •Evan Laufer (In-Person)  
 •Carlos Salampessy (Online)  
 •Kenny Siegel (Online)  
 •Nathan Nguyen (Online)

## Introduction

The Fighting Mongooses worked together to create a modern redesign of the classic Minimoog Model D synthesizer.

- The redesign effort by the team produced an original schematic and PCB layout
- The original design had 6 separate circuit boards with dozens of inline and point to point components.
- The team's design has one single PCB with no inline or point to point components and much less wiring.
- Obsolete parts were replaced with modern and cheaper parts



photo src: <https://www.fantasyspace.com/fip/sound/synthdata/16a-moog-minimoog-int.html> photo src: <https://www.matrixsynth.com/2008/09/inside-moog-minimoog.html>

Original Minimoog internal boards and wiring

## Mongoose Schematic

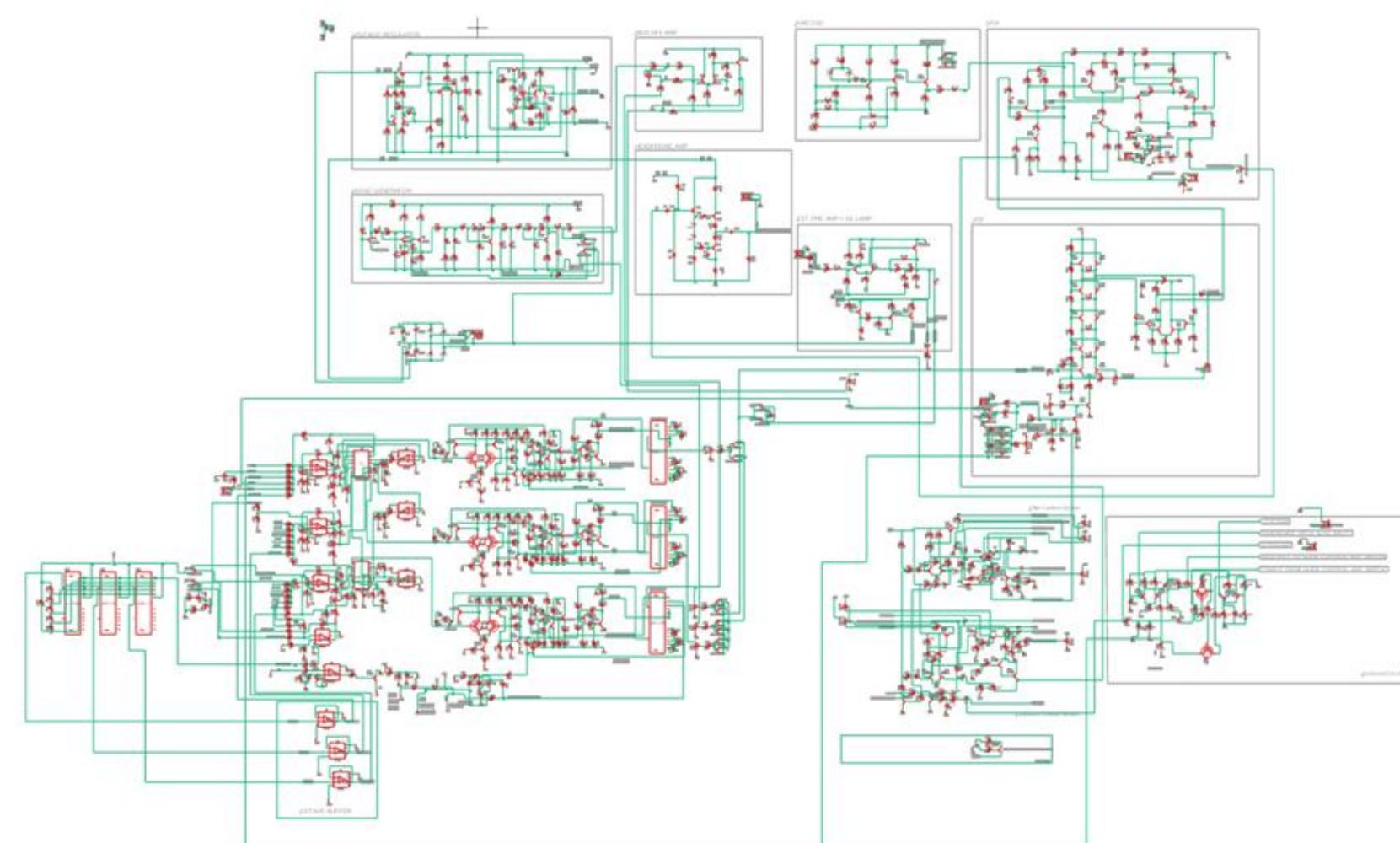

## Simplified Signal Flow

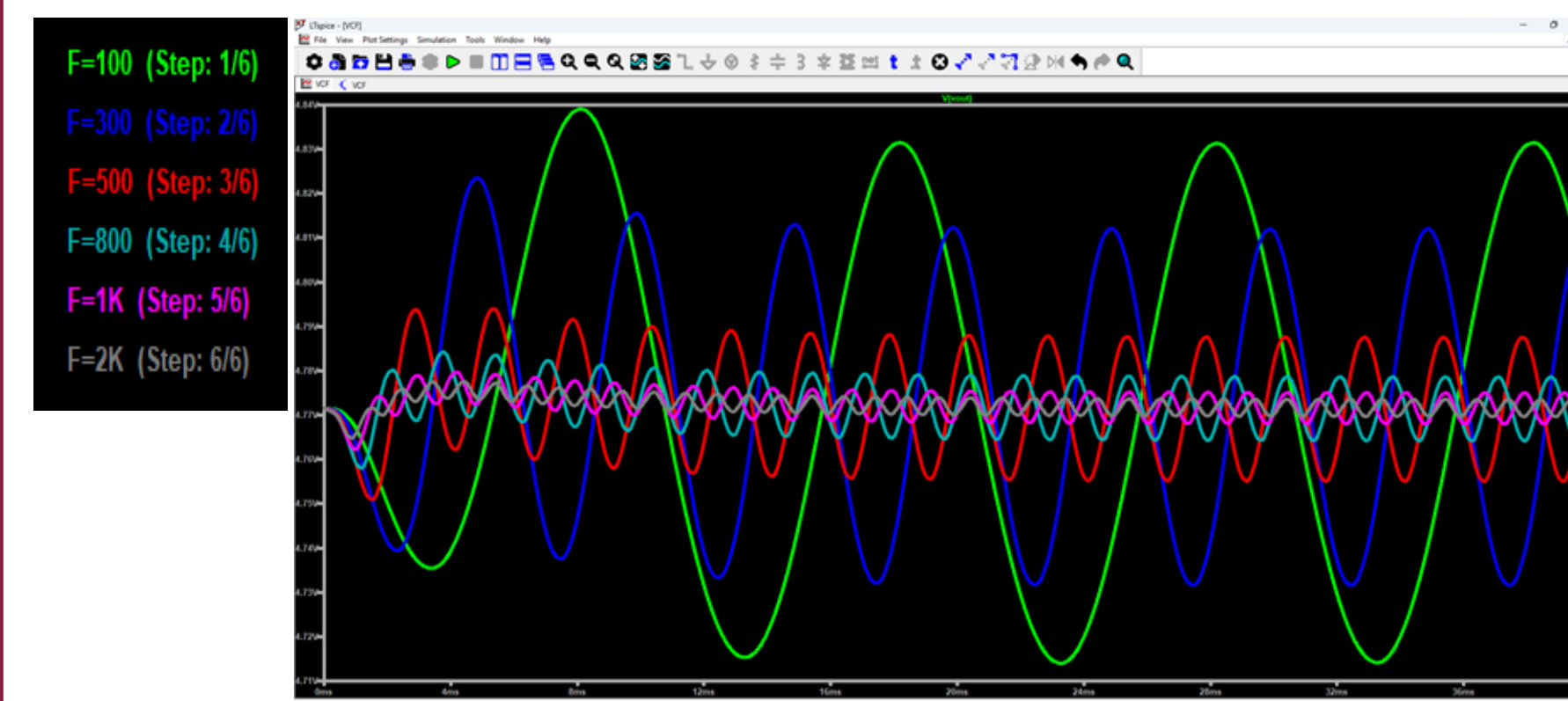
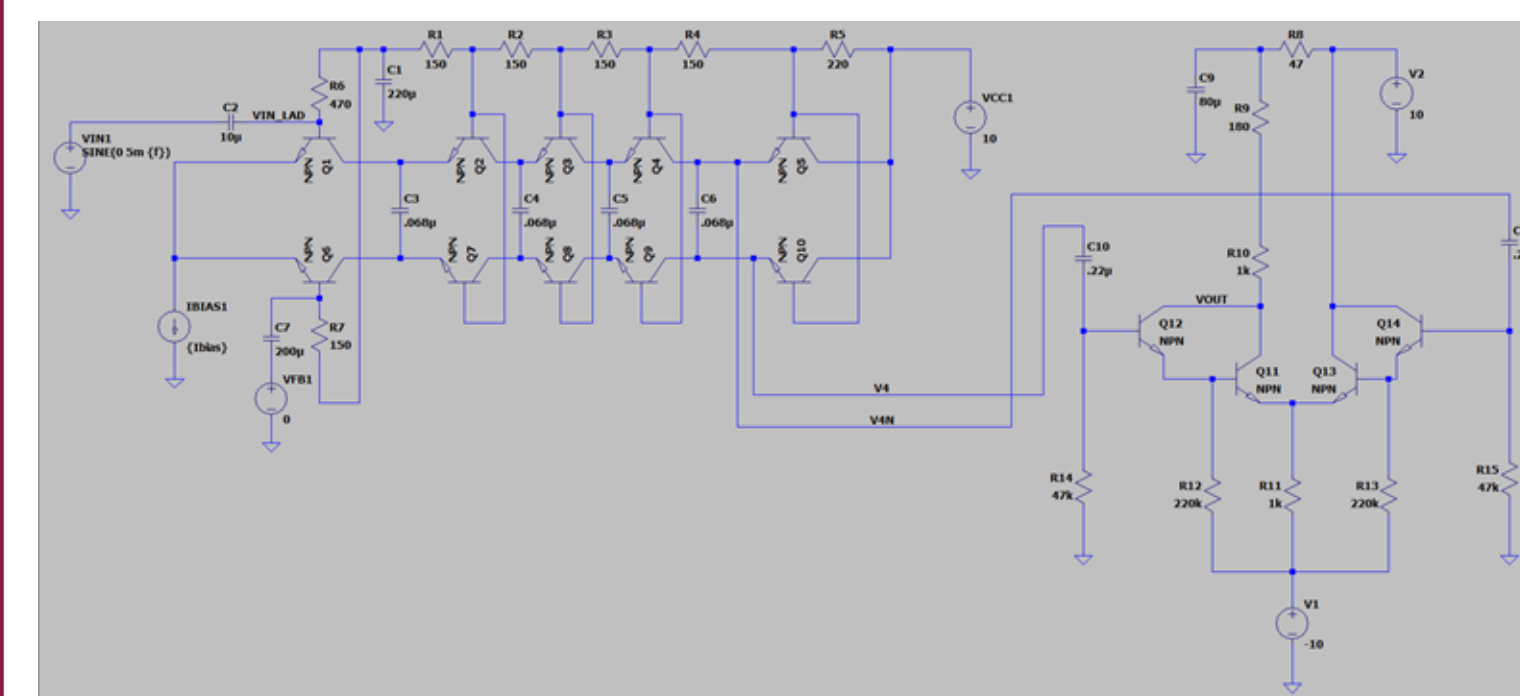
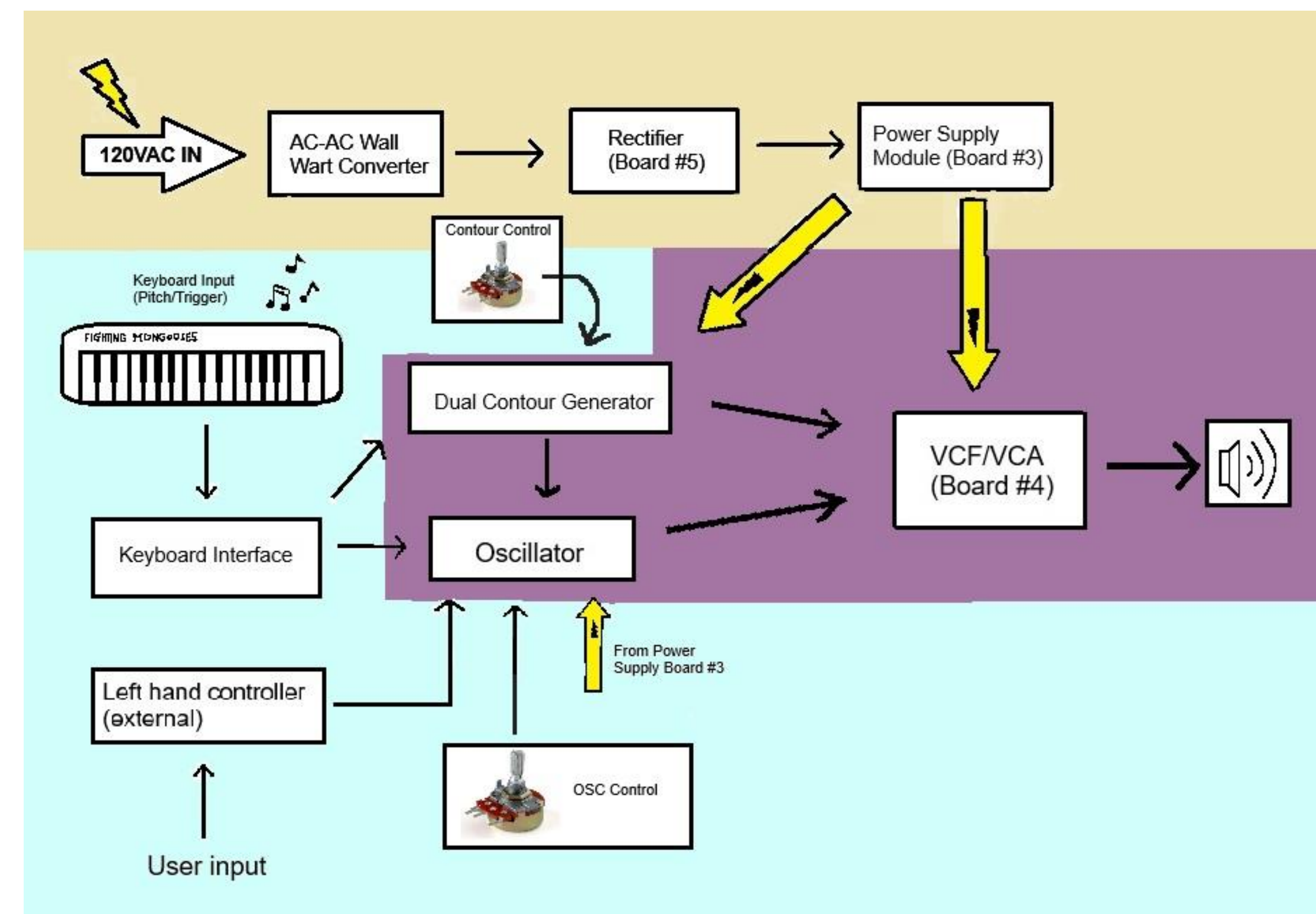

## Simulations

- This is an LTSpice schematic of the VCF (Voltage Controlled Filter) Section of the synthesizer
- An approximation of a sine wave passing through the VCF section of the synth is captured through simulation
- Simulation aims to validate functionality of board before manufacturing

## Results and Presented Design



Rev 3 of the Fighting Mongoose full circuit analog synthesizer PCB Layout

The resulting write up and published design work, as well as Fusion 360 schematic and layout files could potentially be of real value to hobbyists and professional researchers doing similar work.

## Conclusion

There are many modern redesigns of the Minimoog. The Fighting Mongooses took the extra step to try to be as true to the primary source as is reasonably possible.

